

# **AES RAPTOR** **ALL-IN-ONE™**

*Complete Perimeter Fall Protection System*

## *Instruction Manual*



**\*WARNING\***

Serious injury or death may result if this product is used for purposes other than designed. The manufacturer provides the following instructions for the use and care of this equipment. It is the responsibility of the purchaser to understand and convey explicit instruction to each user. The AES Raptor All-In-One™ complies with the requirements of the Federal Occupational Safety and Health Administration (OSHA) when set up and used according to the manufacturers' instructions.

# **AES RAPTOR RAPTORRAIL™ INSTRUCTION MANUAL**

**E  
N  
G  
L  
I  
S  
H**

## **AES Raptor, LLC - All-In-One™ Instruction Manual**

Published by AES Raptor, LLC, North Kansas City, MO

**AES RAPTOR COMPLETE MOBILE FALL PROTECTION SYSTEM**  
is a registered trademark of  
Architectural Exterior Services CORPORATION MISSOURI  
1349 Taney  
North Kansas City MISSOURI 64116  
[www.raptorsafety.com](http://www.raptorsafety.com)

Copyright © 2009 by AES Raptor, LLC

PRINTED IN THE UNITED STATES OF AMERICA

# AES RAPTOR RAPTORRAIL™ INSTRUCTION MANUAL

## DIAGRAM OF PARTS

The All-In-One™ System is comprised of numerous parts. Below is a diagram of all the parts and names, in a parapet clamp mounting configuration.

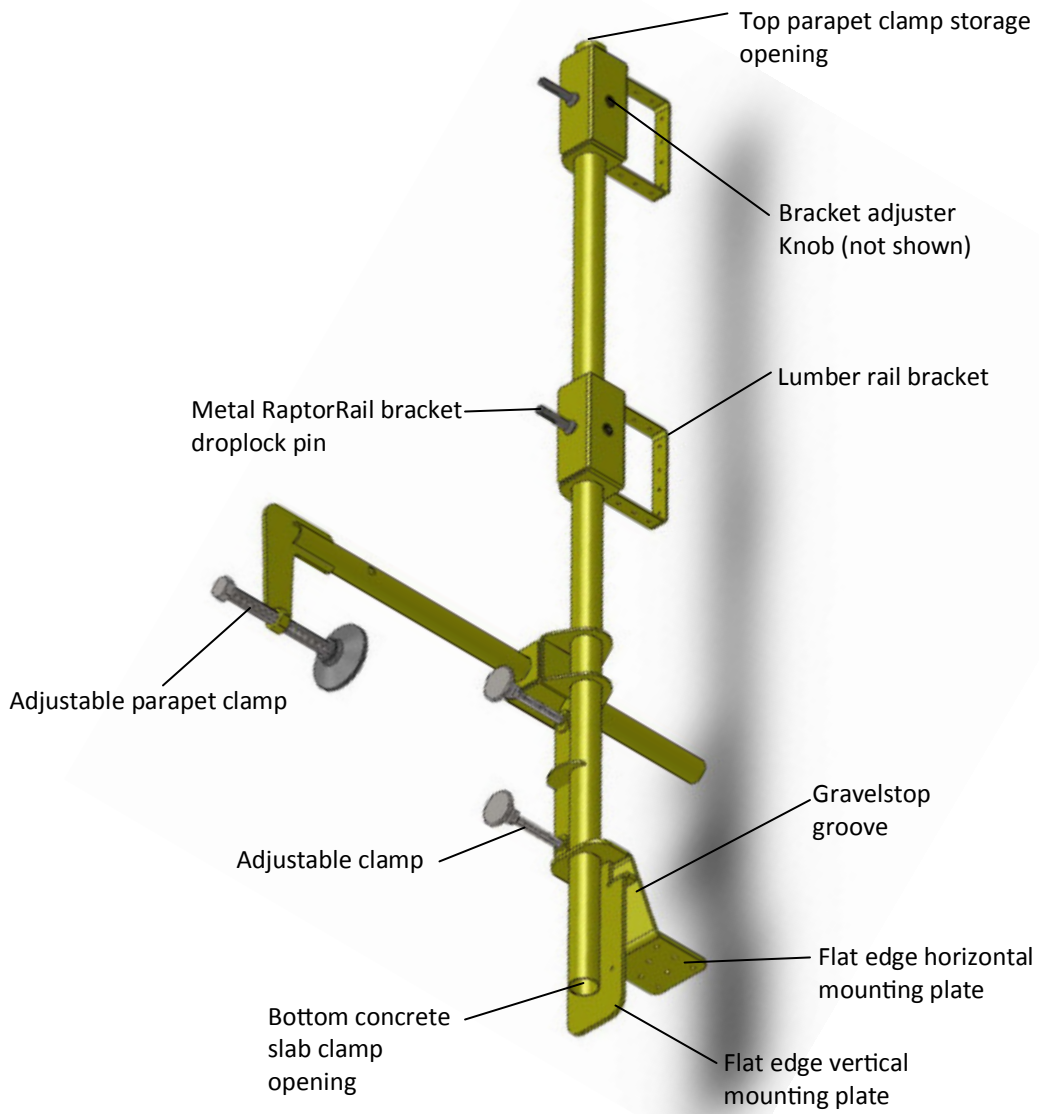

RAPTORRAIL™ COMPONENTS

# AES RAPTOR RAPTORRAIL™ INSTRUCTION MANUAL

## 1.0 Assembly/Setup

- 1.1 The first step in assembling the All-In-One™ system is determining the layout of the roof to be protected. Access points and the need for a ladder access system should be examined. Further, any objects that will interfere with the railing system should be evaluated, and may have to be protected with alternative systems, such as a warning line system for intrusions into the railing system design.
- 1.2 The length of the fasteners used to attach the bases will depend on the structural integrity of the roof system. (Unless the optional parapet clamps are used, in which case no fasteners are needed.) A competent professional should make the determination as to whether or not the length of fastener selected will be sufficient to provide the proper safety margin. If the optional parapet clamps are used, a competent professional will need to determine if the parapet has sufficient strength to provide the proper safety margin. OSHA regulations require that the system be able to withstand a force of 200 pounds applied in an outward or downward direction at any point along the railing system. For more information, refer to OSHA regulation 1926.502(b) "Guardrail Systems".
- 1.3 Determine the first corner from which work will begin. The bases which comprise the corner section should be located no less than 18.5 (eighteen) inches from the actual corner, and no more than 27 (twenty seven) inches from the same corner.

## 2.0 Flat Edge and Gravel Stop Configuration

**Wood Applications:** Four to six #14 coarse thread wood screws with 1.5" penetration per screw in each All-In-One Base into a solid wood base that is either an integral part of the structure or securely attached to the structure.

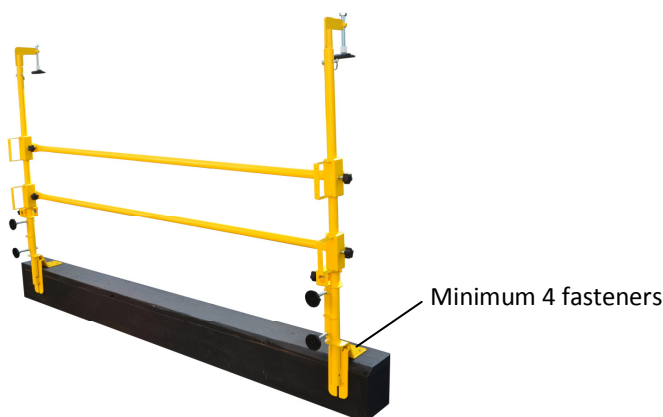

Wood Surface Application

**Concrete Low-Edge Applications:** Four to six #14 coarse thread concrete anchors with 1.5" penetration per screw in each All-In-One Base into a solid concrete base.

**Metal Deck Applications:** Six #14 fine thread metal deck anchors in each All-In-One Base into metal deck securely fastened to the structure.

**Gravel Stops:** Place the base so that the raised area between the horizontal mounting plate and base sits over the gravel stop, and then secure the base just like you would in a flat edge scenario.

# AES RAPTOR RAPTORRAIL™ INSTRUCTION MANUAL

All testing for the All-In-One was done with the above fastener configurations to meet or exceed the OSHA requirements per 1926.502(b) for guardrails. All tests were done with fasteners in the All-In-One base roof / floor surface.

### 3.0 Parapet Walls

If the optional parapet clamps are utilized, the system may be attached without fasteners, provided the parapet itself is of sufficient strength to support the system and meet the OSHA requirement of sustaining 200 pounds of outward or downward force at any point along the railing.

For **parapet walls**, remove the parapet clamp from the storage position and insert it into the horizontal hole with the two tightening knobs. Place the base over the parapet, with the main part of the base on the outer side of the parapet wall and the parapet clamp on the inside (roofside) of the parapet wall.

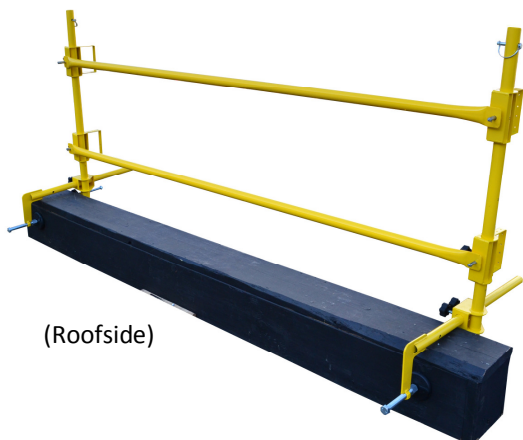

(Roofside)

Parapet Clamp configuration

### 4.0 Concrete Slab Overhangs

4.1 For installations on concrete slab overhangs, insert the parapet clamp attachment into the bottom of the vertical post and secure it by attaching the locking pin.



Concrete Slab Overhang Configuration

# AES RAPTOR RAPTORRAIL™ INSTRUCTION MANUAL

4.2 Tighten the clamp underneath the concrete slab until the base is tightly mounted to the concrete slab.

## 5.0 Installing the Horizontal Rails

5.1 All-In-One™ can be used with metal RaptorRail™ rails or lumber rails.

5.2 To install using metal RaptorRail™ Rails, install the bases the width of the rail (8', 10', or adjustable). Loosen the rail brackets on the vertical posts and turn the brackets so that the railing drop-lock pins are facing in toward the working surface. Then tighten the brackets using the tightening knobs so that the top rail is 42" +/- 3" above the walking/working level. Lastly, slide the metal RaptorRail™ onto the droplock pins.

5.3 To install using wood rails, cut the lumber no more than 9' long. The lumber rail must overlap on either side of the posts by 6". The posts in a wood rail system must be spaced a maximum of 8'. Install the posts and bases at a maximum of 8' apart. Loosen the rail brackets on the vertical posts and turn the brackets so that the wood brackets are facing in toward the working surface. Then tighten the brackets using the tightening knobs so that the top rail is 42" +/- 3" above the walking/working level. Slide the wooden rails into the brackets and secure using at least two wood screws.

## 6.0 General Installation Tips

6.1 After attaching the corner, begin setting up the additional bases at approximately 10 foot intervals. A good technique to ensure the best possible fit is to connect a top rail to an already mounted/fixed base, set up the approximate position of the next base, connect the rail to the top pin, and set up the base in a vertical position. Then connect the mid-rail. When the post/base is connected and verified to be in a fully upright or vertical position, attach the base either using mounting screws or, if using the optional parapet clamps, tighten the clamp.



6.2 Continue this process until the railing system is complete, or until the next corner location. At the corner, place the two corner post/bases no less than 18" and no more than 27" from the actual corner. If the distance between your last post/base and the corner post/base just installed is less than 10 feet, use the adjustable rails for optimum fit.

## 7.0 Applications

7.1 The All-In-One™ is to be used as a railing system for roofs and intermediate level floors. The All-In-One™ may be used where worker mobility and fall protection are required.

7.2 The All-In-One™ should be used as a part of a complete fall protection system plan.

- 7.3 The All-In-One™ can be used with many different types of roofing, decking, edge, or parapets providing a competent professional has determined that the roof, deck, or edge is capable of withstanding the weight of the All-In-One™ system, and the OSHA required ability to withstand a 200 pounds force applied outward or downward anywhere on the All-In-One™ system.

If the parapet clamps are used, a competent professional will need to determine if the parapet has sufficient strength to provide the proper safety margin. OSHA regulations require that the system be able to withstand a force of 200 pounds applied in an outward or downward direction at any point along the railing system. For more information, refer to OSHA regulation 1926.502(b) "Guardrail Systems".

## 8.0 Damage to Rail

After sustaining damage: Equipment which has been subject to damaging forces must be removed from service immediately for inspection.

## 9.0 Before Each Use

- 9.1 OSHA 1926.502 requires that before operating the system there must be an inspection for damaged equipment.

### INSPECTION STEPS

STEP 1: Check for loose, bent or damaged parts.

STEP 2: Check fasteners/connectors for distortion, cracks, or other damage.

STEP 3: Check for corrosion on Parts.

### MAINTENANCE AND CARE:

- A. Inspect all AES Raptor equipment and parts before and after each use.
- B. Regularly inspect all fasteners. Damaged or missing parts can severely hinder the safety factor of the All-In-One™.
- C. Maintain paint finish to prevent corrosion.

## 10.0 General Safety

- 10.1 USE COMMON SENSE! Most accidents can be avoided by using common sense and concentrating on the job to be done.
- 10.2 The All-In-One™ system should not be used by persons whose ability or alertness is impaired by fatigue, intoxicating beverages, illegal or prescription drugs, or any other physical cause that exposes the user or others to injury.
- 10.3 Always wear proper safety attire.



[WWW.RAPTORSAFETY.COM](http://WWW.RAPTORSAFETY.COM)

**1-888-990-2990**