



P.O. Box 531
Lafayette Hill, PA 19444
(tel) 610 941-4333
(fax) 610 941-4336

OPERATING & INSTRUCTION MANUAL

PARTS MANUAL INCLUDED

★ IMPORTANT ★
Retain This Manual
for instructions on assembly and operation of HOIST

READ THIS MANUAL CAREFULLY BEFORE ATTEMPTING TO ASSEMBLE OR OPERATE. FAILURE TO COMPLY WITH INSTRUCTIONS MAY CAUSE THE HOIST TO MALFUNCTION AND MAY RESULT IN PERSONAL INJURY.

MODEL • 123

I. SAFETY INSTRUCTIONS

Note: The safety instructions and warnings in this section and throughout this manual must be read carefully before assembling or operating the Hoist. These safety instructions and warnings are not substitutes for routine accident prevention measures which must also be implemented to eliminate potential risks and hazards. Failure to obey these safety warnings may result in injury to you or others, or damage to the Hoist.

A. SAFE ASSEMBLY

1. **Transporting Your Hoist**—To avoid damage, handle Hoist component parts with care when transporting.
2. **Unpacking Your Hoist**—When unpacking Hoist component parts, inspect carefully for any damage that may have occurred during transit. **DO NOT ASSEMBLE OR USE THE HOIST IF ANY PART IS DAMAGED!** Return the damaged part to place of purchase for replacement.
3. **Safety Labels**—Observe all labels and instructions attached to the various parts of the Hoist.
4. **Proper Parts**—For your safety, use only attachments and accessories approved by the manufacturer for use with the Hoist.
5. **Safety Check**—Check assembled parts (splice plates, bolts, engine mounting, belts, pulleys, hoist cable, etc.) for proper tightness and fit before using the Hoist, and at frequent intervals during periods of use, to be certain the equipment is in safe working condition.
6. **Bracing Your Hoist**—Never place or operate the Hoist on a slippery surface and make certain it is properly secured at the base to prevent slippage or unexpected movement. Make sure the Hoist is braced against a building or solid abutment at the correct angle prescribed herein.
7. **Housekeeping**—Clear the area around the base of the Hoist to avoid slipping, tripping, or falling against the Hoist.
8. **Fueling**—Handle fuel with care. It is extremely flammable and highly explosive under certain conditions.
 - a. Never smoke or allow open flames or sparks to be present in the area when the fuel tank is being filled.
 - b. Use an approved fuel container.
 - c. Never add fuel to a hot or running engine.
 - d. Replace fuel caps securely on the supply container and engine tank and wipe fuel spilled before starting engine.
9. **HAZARDS—DO NOT PLACE OR USE THIS METAL HOIST IN AN AREA WHERE IT COULD COME IN CONTACT WITH ELECTRICAL WIRING CIRCUITS, OR ANY OTHER HAZARDOUS OBSTRUCTION.**

B. SAFE OPERATION

1. Proper Instructions—DO NOT ALLOW ANYONE TO OPERATE THE HOIST WHO HAS NOT BEEN PROPERLY AND THOROUGHLY TRAINED IN ITS OPERATION AND USE.
2. Enclosed Areas—Do not operate the engine indoors. Exhaust fumes can be hazardous in enclosed areas.
3. **WARNING—USE THE HOIST FOR LIFTING MATERIALS ONLY. THE HOIST SHOULD NEVER BE USED TO TRANSPORT A PERSON FROM ONE ELEVATION TO ANOTHER.**
4. Maximum Capacity—THE MAXIMUM CAPACITY OF THE HOIST IS 200 POUNDS. Do not overload.
5. **WARNING—KEEP HANDS, FEET, OTHER BODY PARTS, AND CLOTHING WAY FROM TRACK, AND MOVING OR ROTATING PARTS OF THE HOIST WHEN STARTING THE ENGINE OR OPERATING THE HOIST.**
6. CAUTION—Do not allow anyone to walk or work under the Hoist while it is in operation.
7. Molten Substances—Do not use the Hoist to lift buckets of hot asphalt or any other hot, molten substance.
8. Supervision—Stop the engine whenever you leave the vicinity of the Hoist.

C. DISASSEMBLY AND STORAGE

1. After stopping the engine, wait for all moving parts to stop, and for the engine to cool before disassembling.
2. Disconnect the spark plug wire from the plug.
3. Storage of the Engine—Never store the engine in any enclosure before cooling.
4. Storage of Power Unit—Do not store the power unit with fuel in its tank in any enclosure where flames or sparks may be present.
5. Storage of Component Parts—Store the power pack unit upright and hang the ladder parts from a side wall to prevent damage.

II. SPECIFICATIONS

- ** 3.5 h.p. Gasoline Engine (B/S Briggs/Stratton)
- ** 200lb. Maximum Hoisting Capacity
- ** 80 ft. 1/8" STEEL/GALV. Cable
- ** 100% Ball Bearing Winch
- ** Steel Carriage w/Rollers
- ** 27 ft. alum. track sections (3-8ft. & 1-3ft. base)

I23 HOIST

see parts list for replacement parts

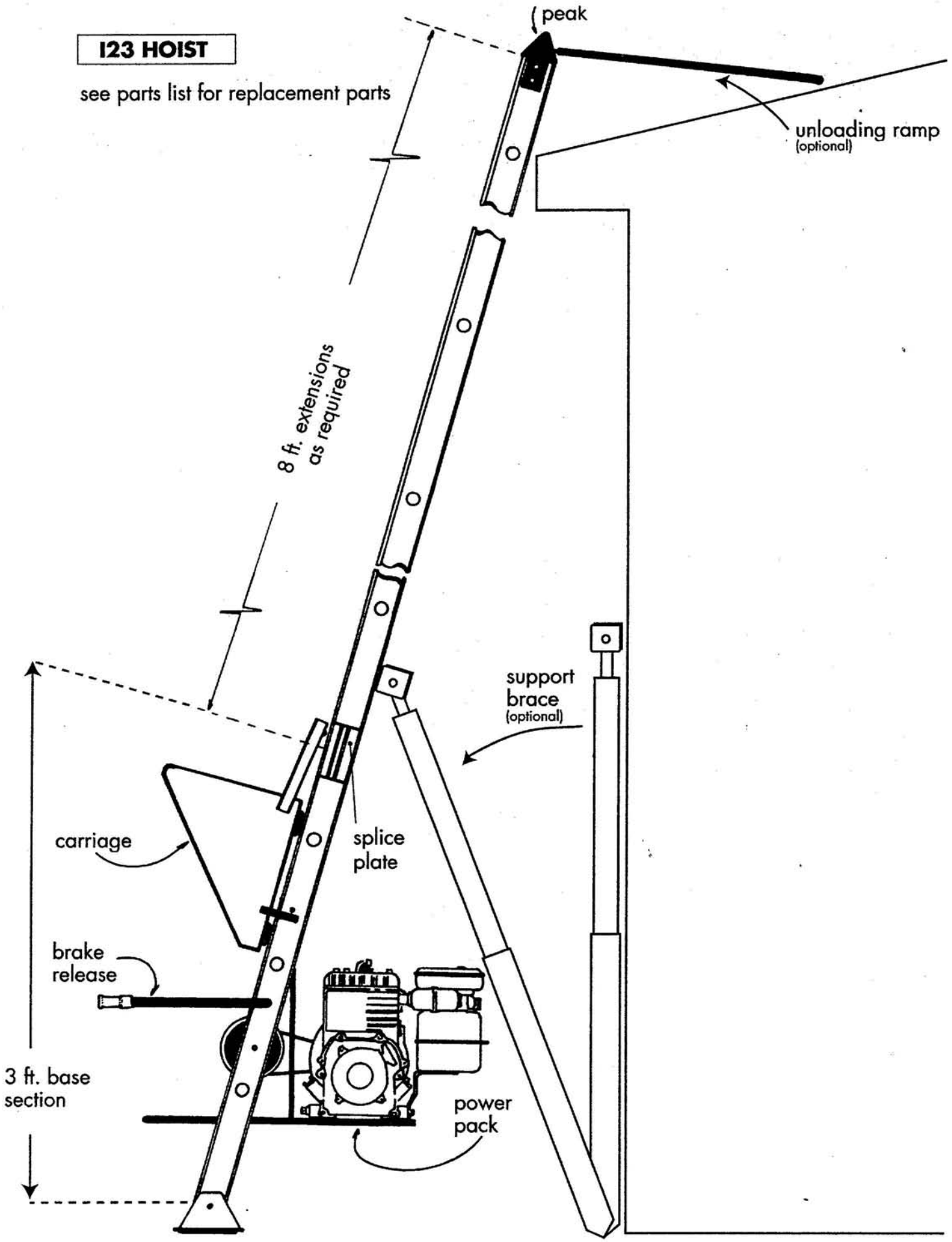

(peak)

unloading ramp
(optional)

8 ft. extensions
as required

support
brace
(optional)

splice
plate

carriage

brake
release

3 ft. base
section

power
pack

III. HOW TO ASSEMBLE AND OPERATE YOUR HOIST

A. HOW TO ASSEMBLE YOUR HOIST PROPERLY

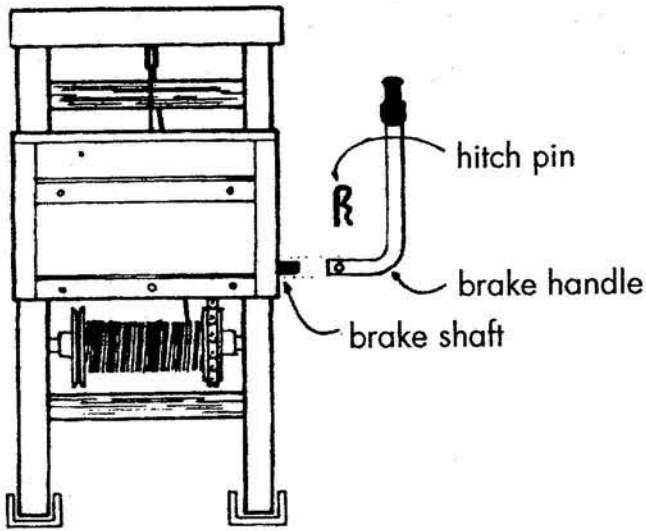

1. Lay 3 ft. base section flat on ground with carriage facing up. Install brake handle using hitch pin provided.
2. Remove peak from base section (do not disconnect cable). Draw out peak approximately 9 ft. from base by releasing brake. (Illustration I.) Assemble one extension section at a time; be certain cable runs around extension. Use splice plates provided and securely fasten with nuts and bolts provided (Illustration II.) Add additional sections as required by repeating this procedure.

Illustration I

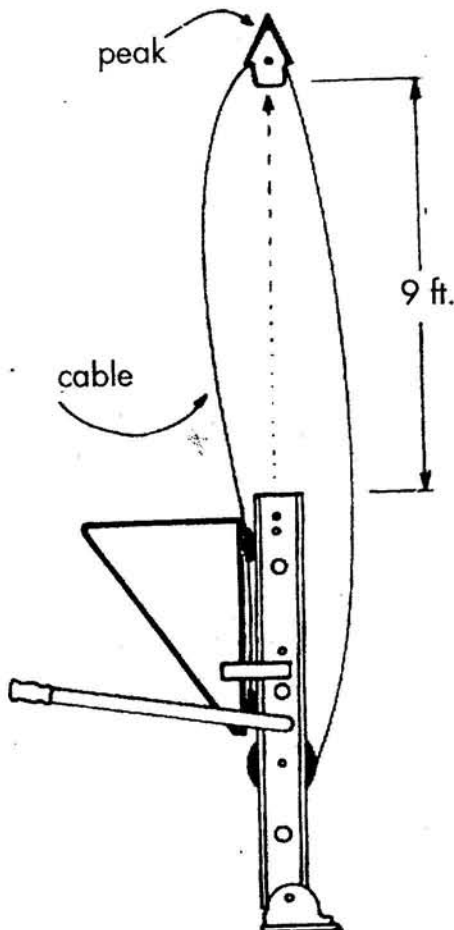
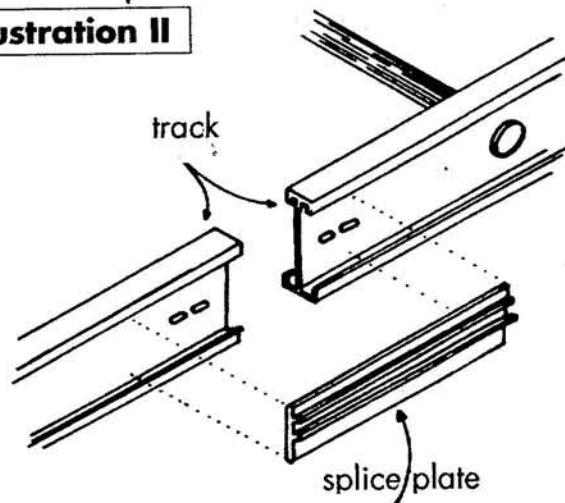
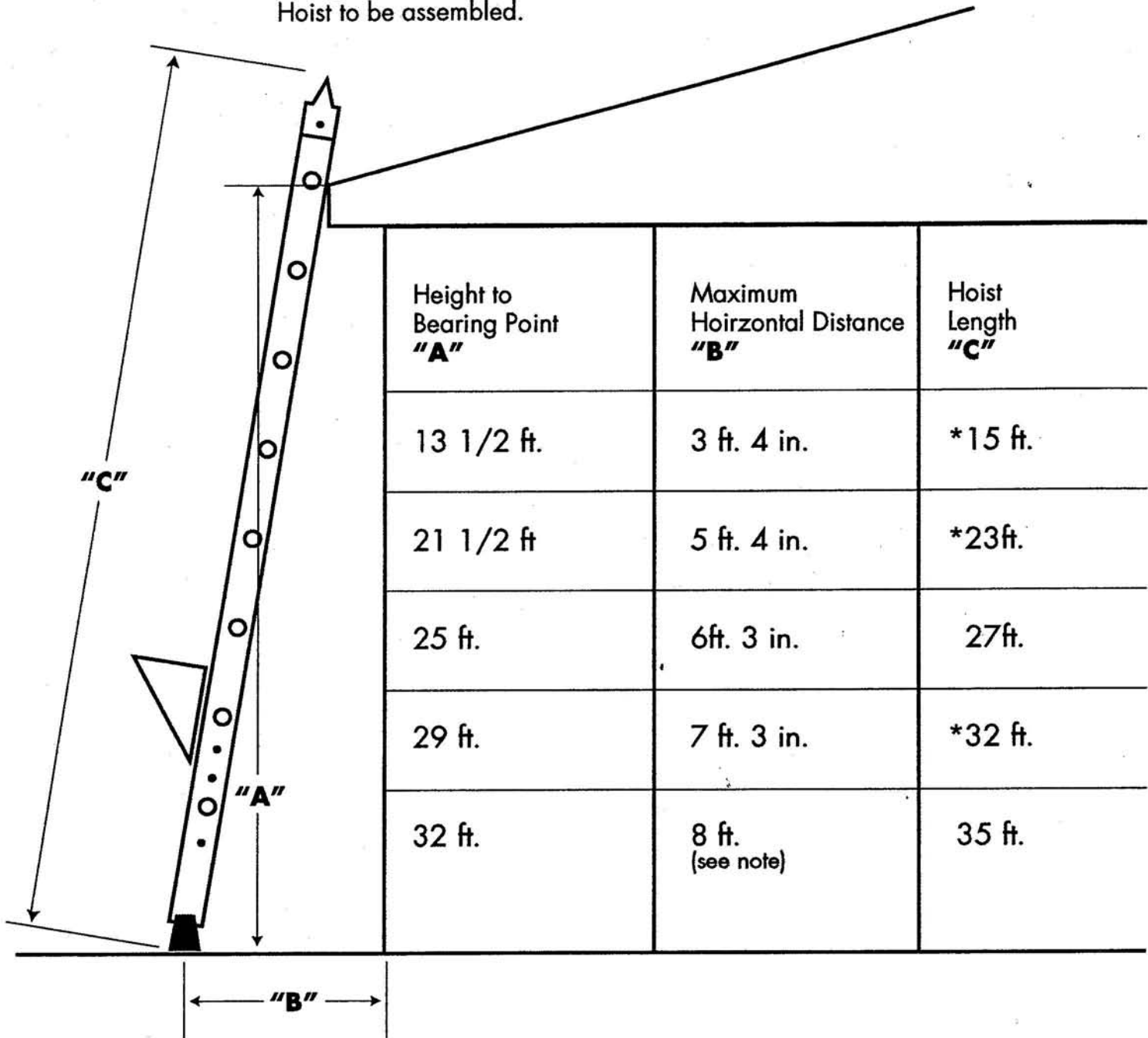

Illustration II



3. Once Hoist is assembled to desired length, attach peak to top section and fasten with the nuts and bolts provided.
4. Place Hoist against building at the proper safe angle. Use the chart below as a guide to determine the angle of incline of the Hoist for the length of the Hoist to be assembled.



*These lengths are obtainable by using an optional 4 ft. extension

NOTE: Distance "B," the maximum horizontal distance, must not be more than 1/4 of the Hoist's working length "A."

5. Attach power pack to Hoist by hooking unit over cross shaft located above second extension rung. Once in position, check power pack unit for free backward movement so that drive belt can fully engage the winch drum assembly.

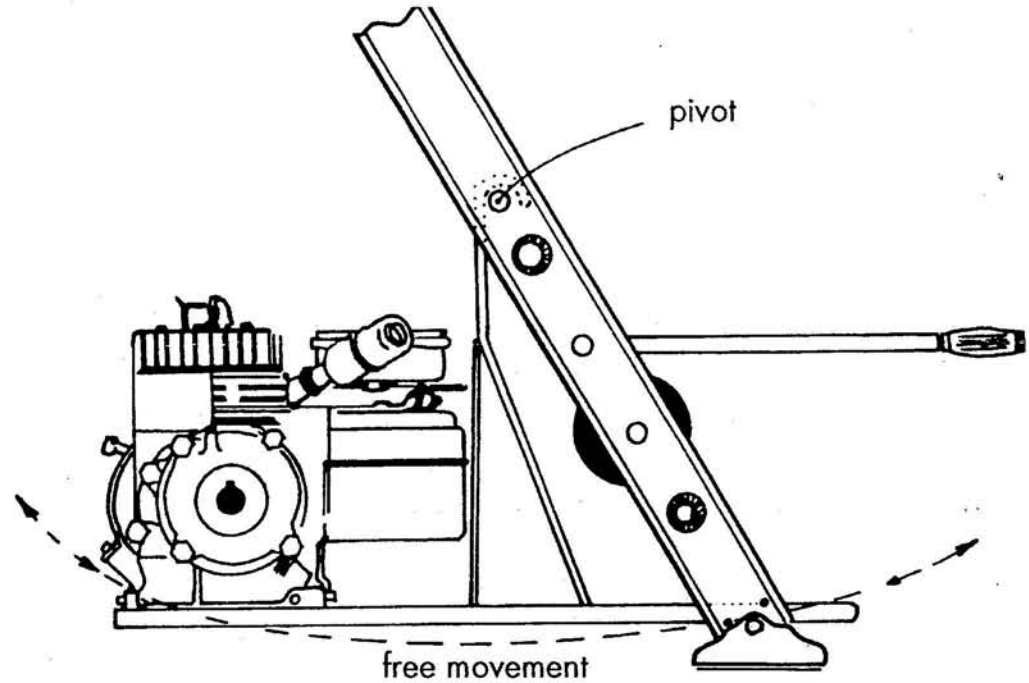

6. Install drive belt on motor drive pulley. Place belt between guide bolts as shown.

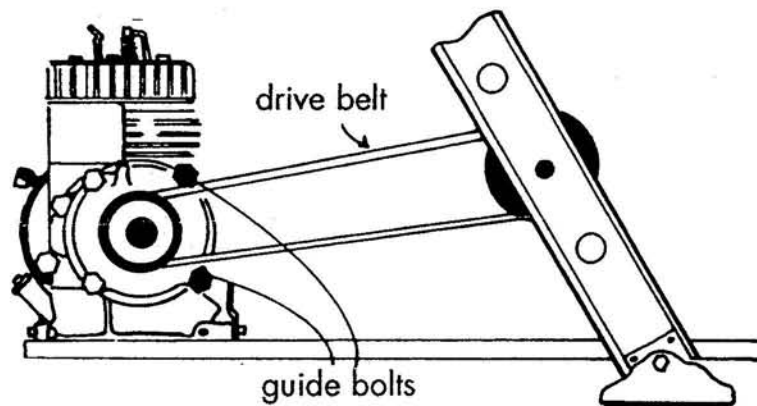

B. HOW TO OPERATE YOUR HOIST

1. Before starting engine:
 - a. refer to motor "operating instructions" for starting, oil and gasoline specifications.
 - b. *CAUTION—Make certain the drive belt is not engaged with the winch assembly drum to prevent activating the carriage assembly.*
2. Start the engine and adjust throttle so that the engine runs at idle speed. The operator should then make a trial test run with the Hoist. The test should be done while the carriage assembly is not loaded with material and should be run in accordance with instructions for proper operation.
3. After completing the trial run, return the carriage assembly to the base position and load the hoisting carriage with material. Material should be placed flat and evenly at the center of the carriage platform.

CAUTION: DO NOT EXCEED THE 200 POUND WEIGHT LIMIT

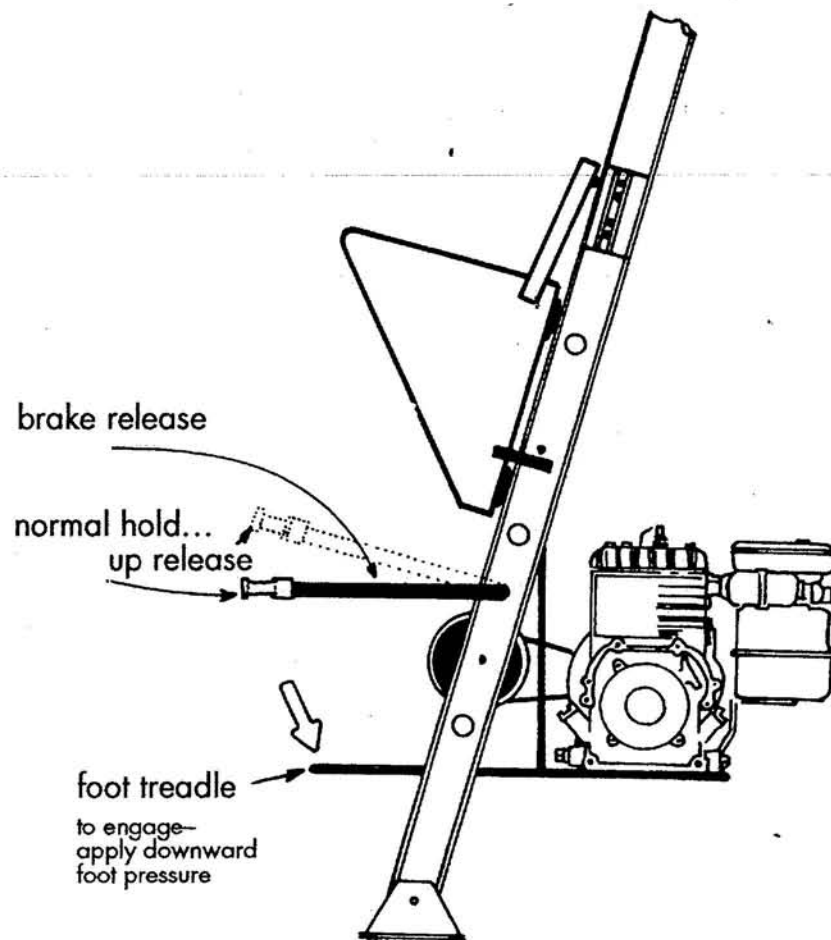

4. Manually increase engine speed to full throttle.
5. With engine at full throttle, apply foot pressure on treadle. this will engage winch and start carriage in its upward travel. Foot pressure on the motor base assembly treadle must be maintained throughout the upward travel of the carriage assembly.
6. Once carriage starts its upward travel do not stop its motion until it reaches peak. Upon load reaching peak, release foot pressure and the load will discharge down the unloading ramp.

NOTE: Should you stop carriage in midclimb, brake will hold load. Do not return loaded carriage to ground. Reapply foot pressure on treadle and complete hoisting.

7. Once load is discharged:
 - a. Manually release throttle and idle engine. Brake is always on. Therefore, by lifting up on handle, brake will release.
 - b. **CAUTION—Upon releasing brake, carriage will free fall. Allow the carriage to lower about 12 inches at a time as it descends by releasing the brake action slowly at steady intervals.**



P.O. Box 531
Lafayette Hill, PA 19444
(tel) 610 941-4333
(fax) 610 941-4336

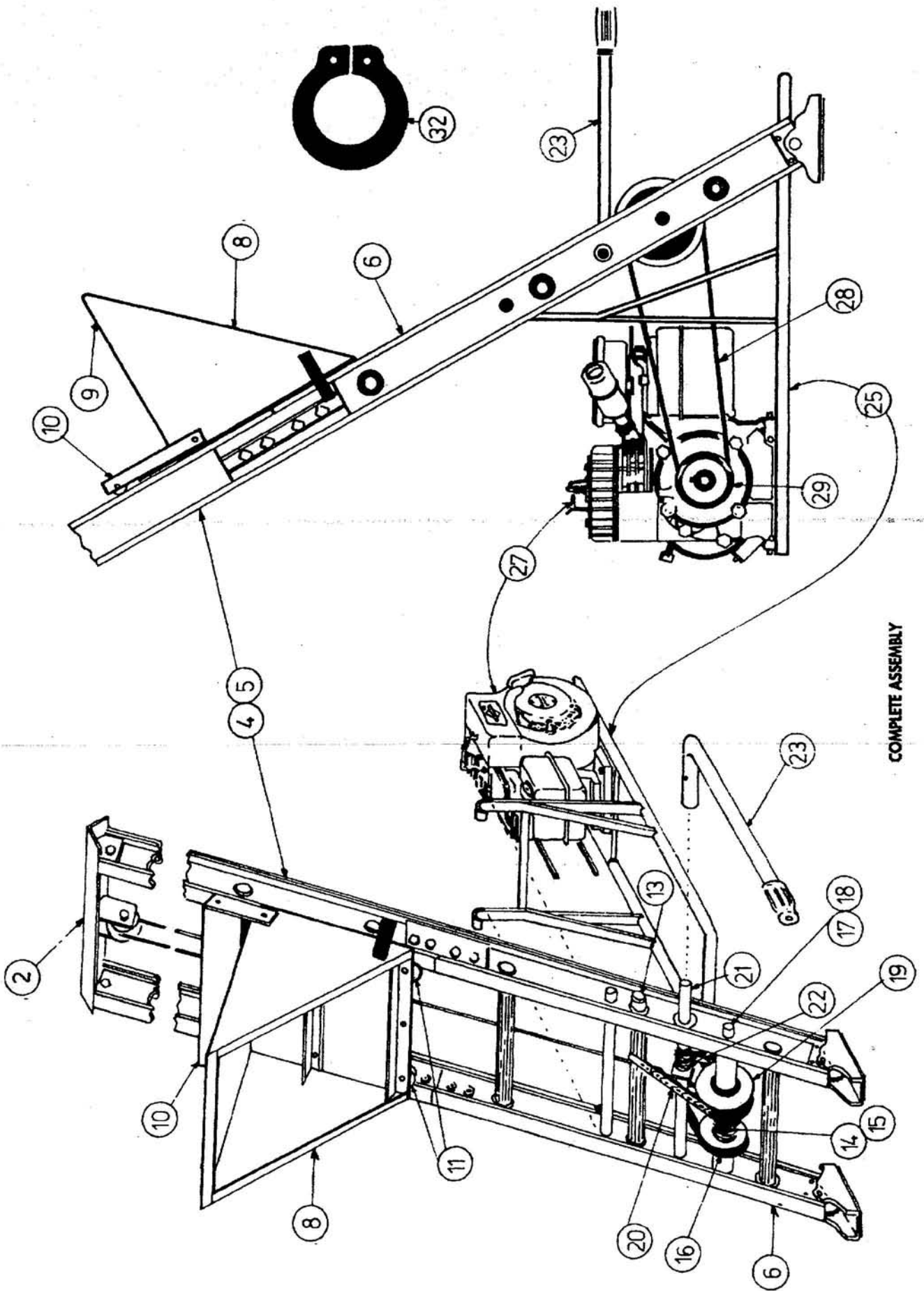

COMPLETE ASSEMBLY

NOTE: Match part number on drawing with item number below

ITEM #	DESCRIPTION
2.	Complete top pulley assembly (peak)
4.	4 ft. extension
5.	8 ft. extension
6.	3 ft basic section with shoes
8.	Complete carriage assembly
10.	Carriage flap w/2 skate wheels
11.	Carriage wheel each
13.	Carriage stop pipe
14.	80 ft. wire cable with thimble (complete)
15.	100 ft. wire cable with thimble (complete)
16.	Winch drum with pulleys and fasteners
17.	Winch drum bearings w/fasteners each
18.	Winch drum shaft w/fasteners
19.	Winch drum assembly (drum, pulleys, 2 bearings, drum shaft w/fasteners)
20.	Brake band
21.	Brake cross shaft w/fasteners
22.	Brake spring w/fasteners
23.	Brake handle w/hitch pin
25.	Motor base (less motor)
27.	3.5 H.P. gas engine
28.	Drive belt w/fasteners
29.	Motor drive pulley w/key way
32.	C-type fasteners each

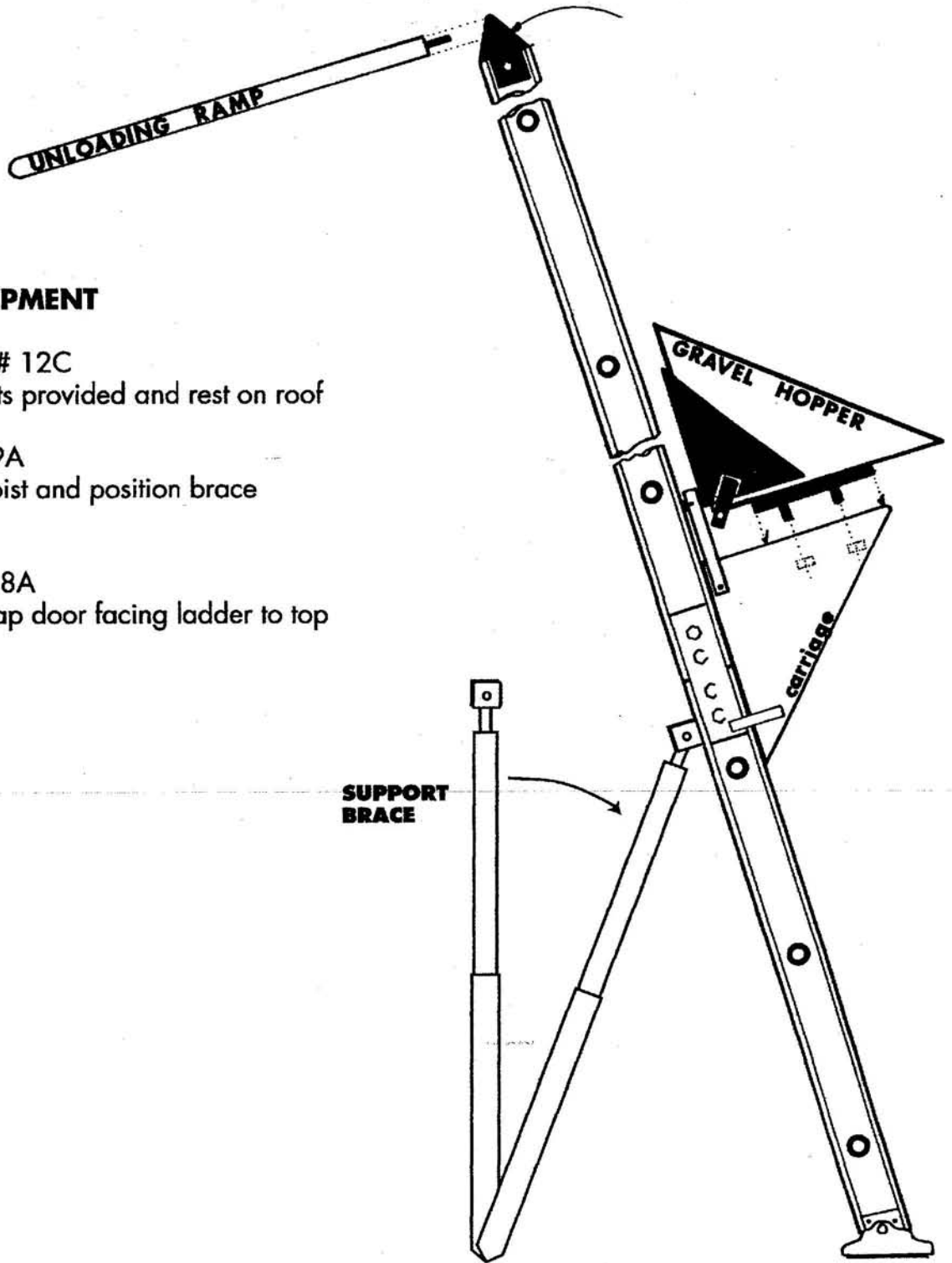

OPTIONAL EQUIPMENT

Unloading Ramp- # 12C
Guide pins into slots provided and rest on roof

Support Brace- # 9A
Locate center of Hoist and position brace
between rungs

Gravel Hopper- # 8A
Bolt hopper with trap door facing ladder to top
of carriage.